

WALKO-Table Top dimensions 1/4 (In millimeters)

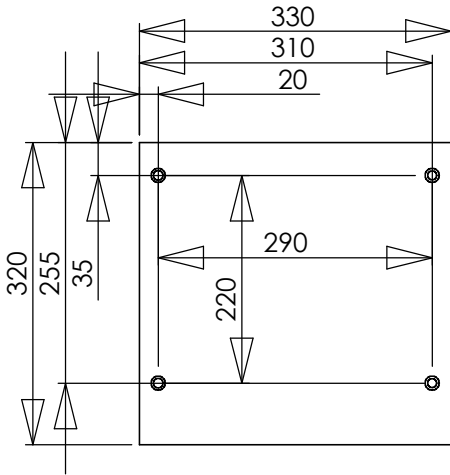

1. Single

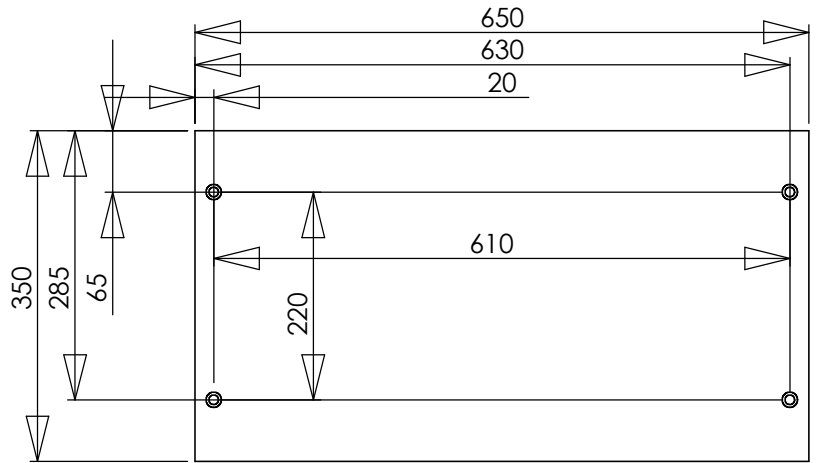

2. Double

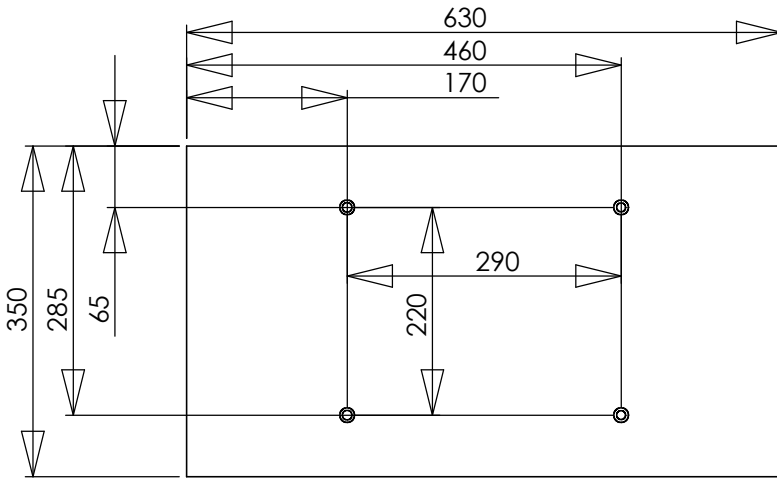

3. Single with wide sides

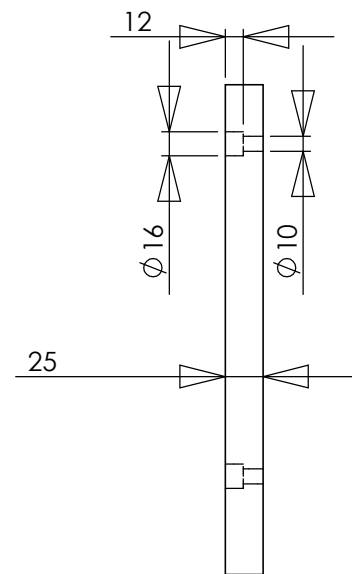

Suggested Holes for all tops

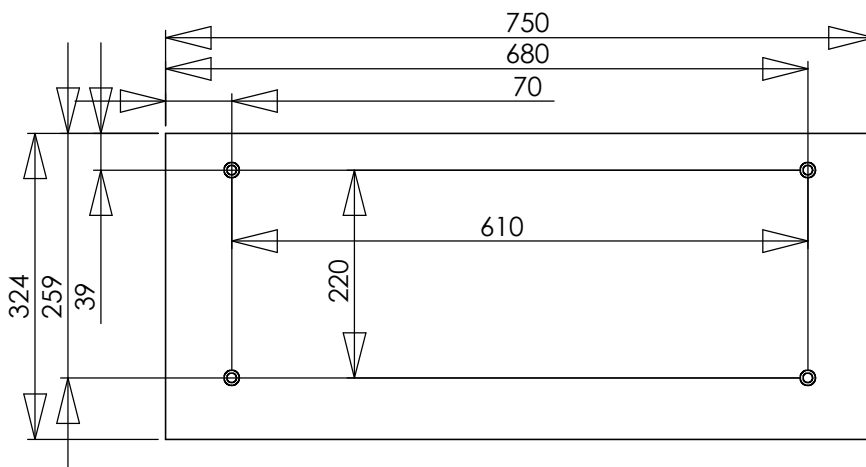

4. Double (WALKO-3 Table)

When machines are placed on a WALKO always follow the manufacturers instructions for this machine.
 Do not make the tables too big, prevent the WALKO for tipping over.
 Work safe, Think twice.
 WALKO-Tools BV can not be held responsible for self made table tops.
 All information on these sheets under the usual reservations of format and printing errors.

WALKO-Table Top dimensions 2/4 (In millimeters)

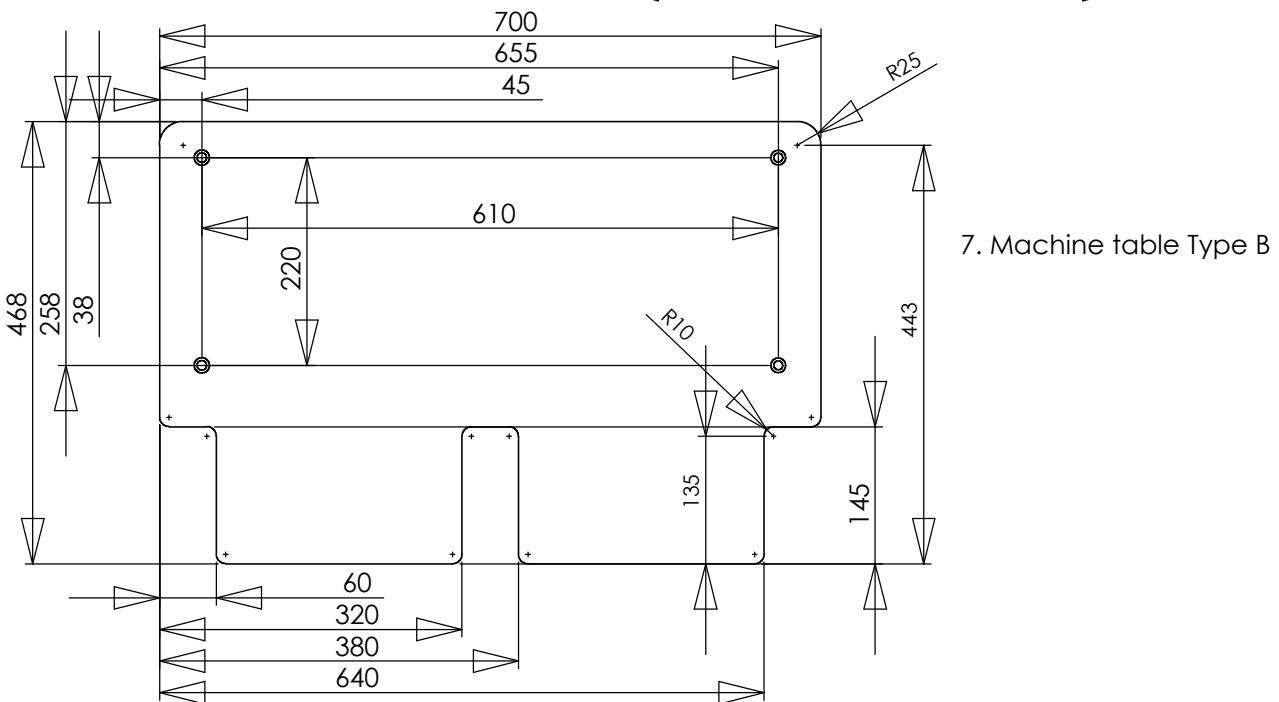
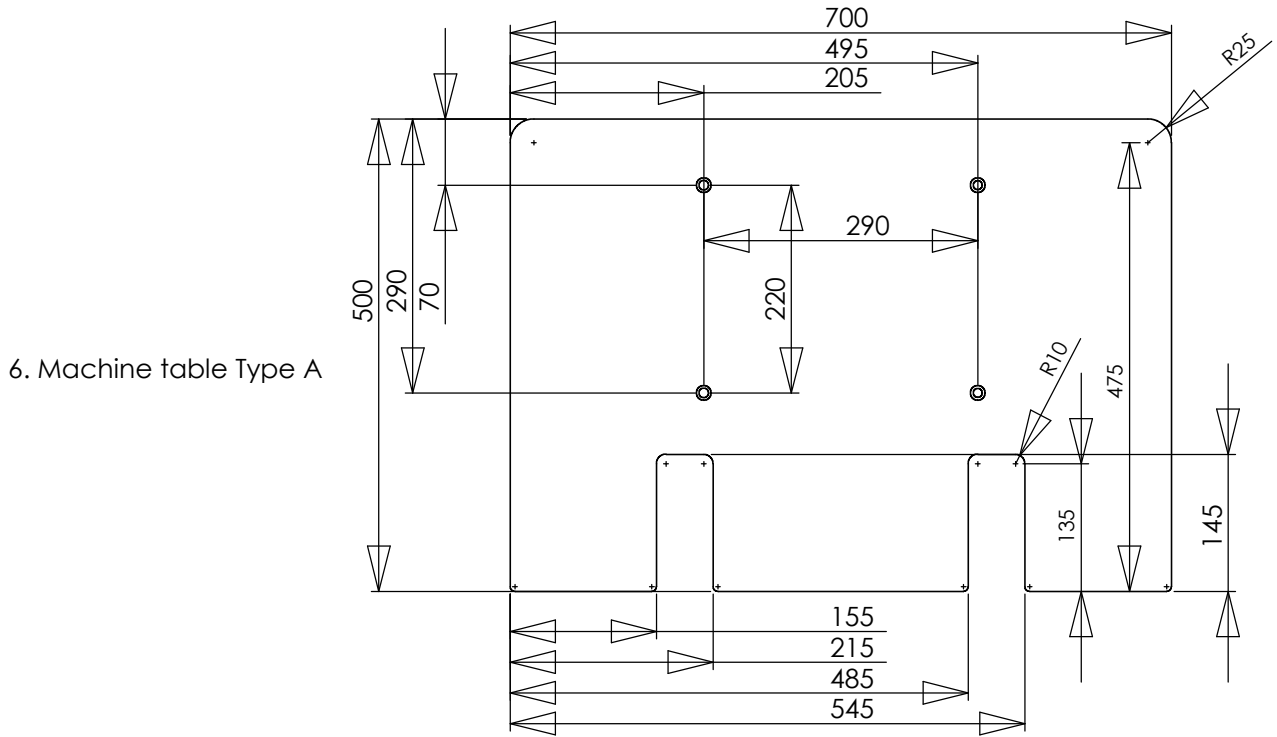
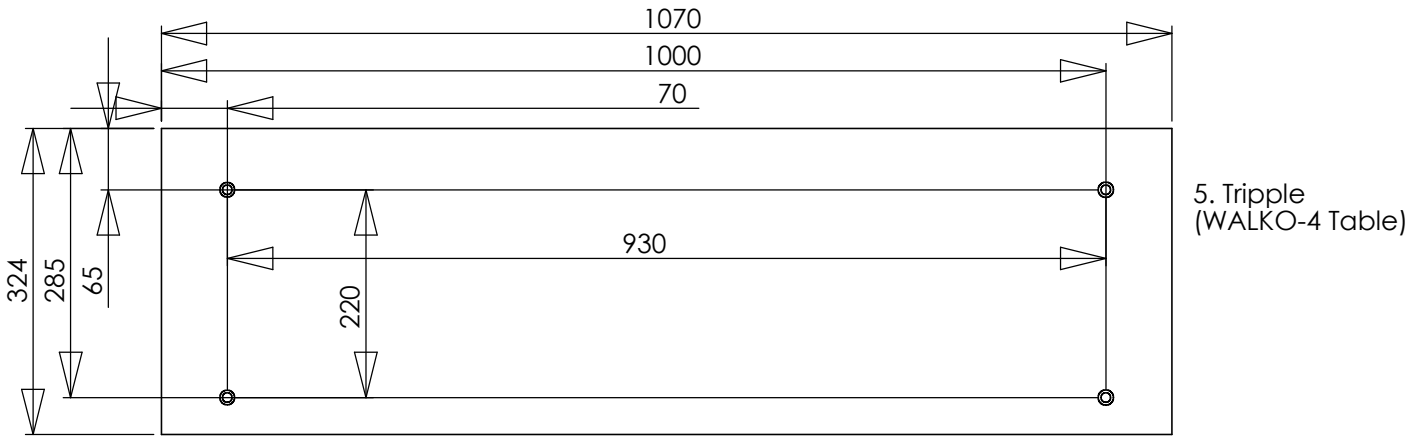

When machines are placed on a WALKO always follow the manufacturers instructions for this machine.
 Do not make the tables too big, prevent the WALKO for tipping over.
 Work safe, Think twice.
 WALKO-Tools BV can not be held responsible for self made table tops.
 All information on these sheets under the usual reservations of format and printing errors.

WALKO-Table Top dimensions 3/4 (In millimeters)

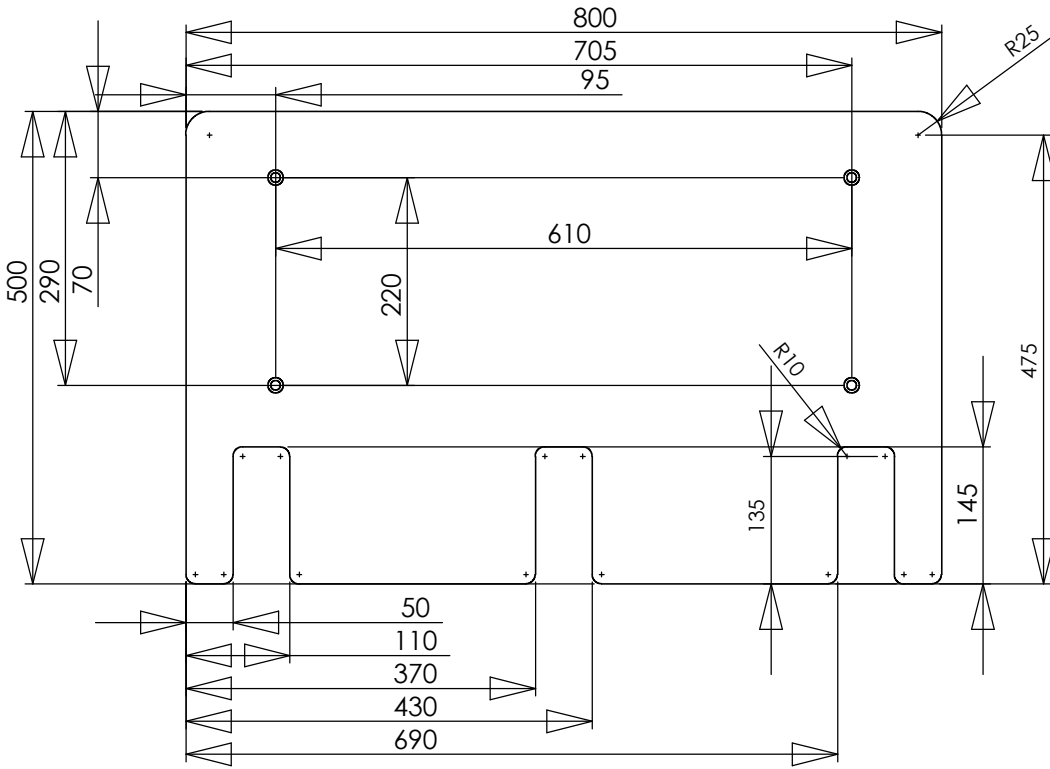

8. Machine table Type C

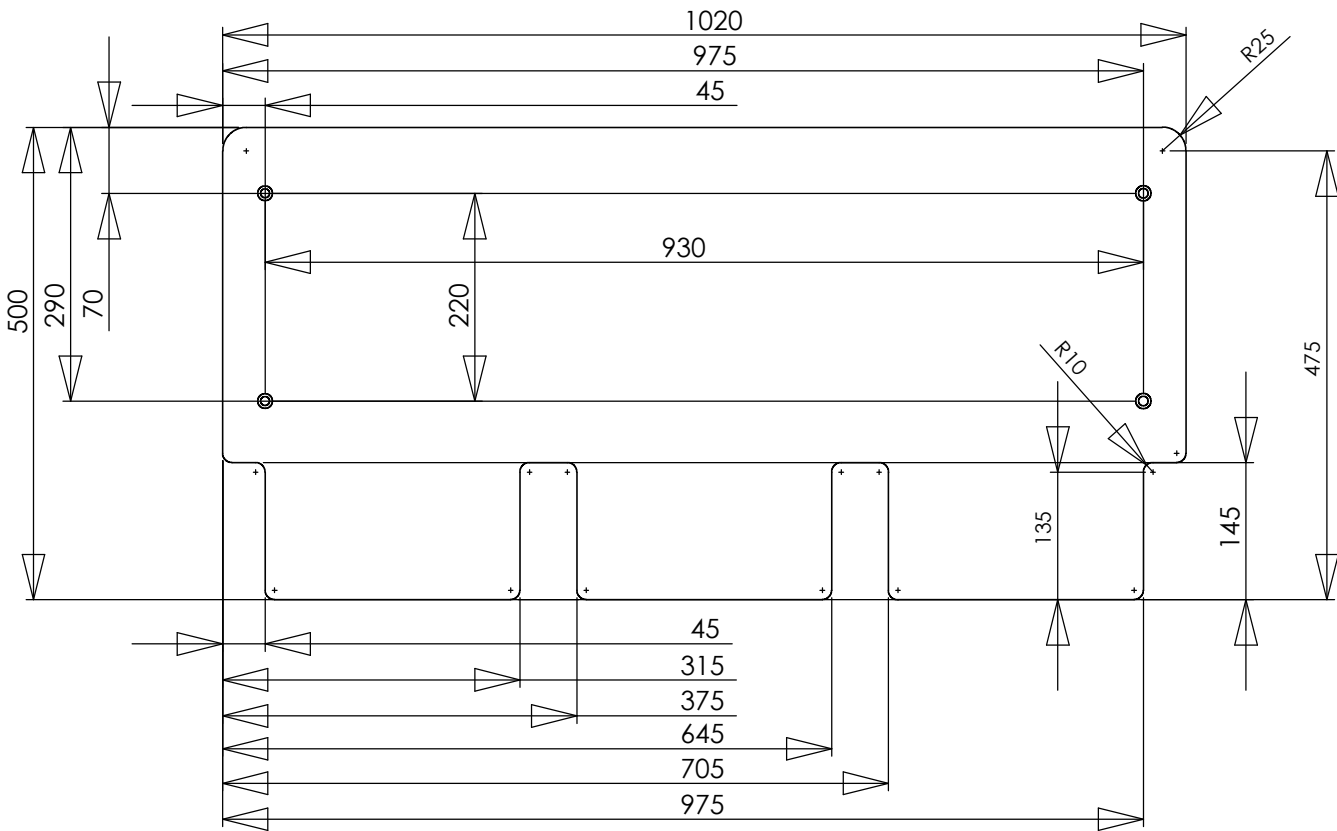

9. Machine table Type D

When machines are placed on a WALKO always follow the manufacturers instructions for this machine.
 Do not make the tables too big, prefer the WALKO for tipping over.
 Work safe, Think twice.
 WALKO-Tools BV can not be held responsible for self made table tops.
 All information on these sheets under the usual reservations of format and printing errors.

WALKO-Table Top dimensions 4/4 (In millimeters)

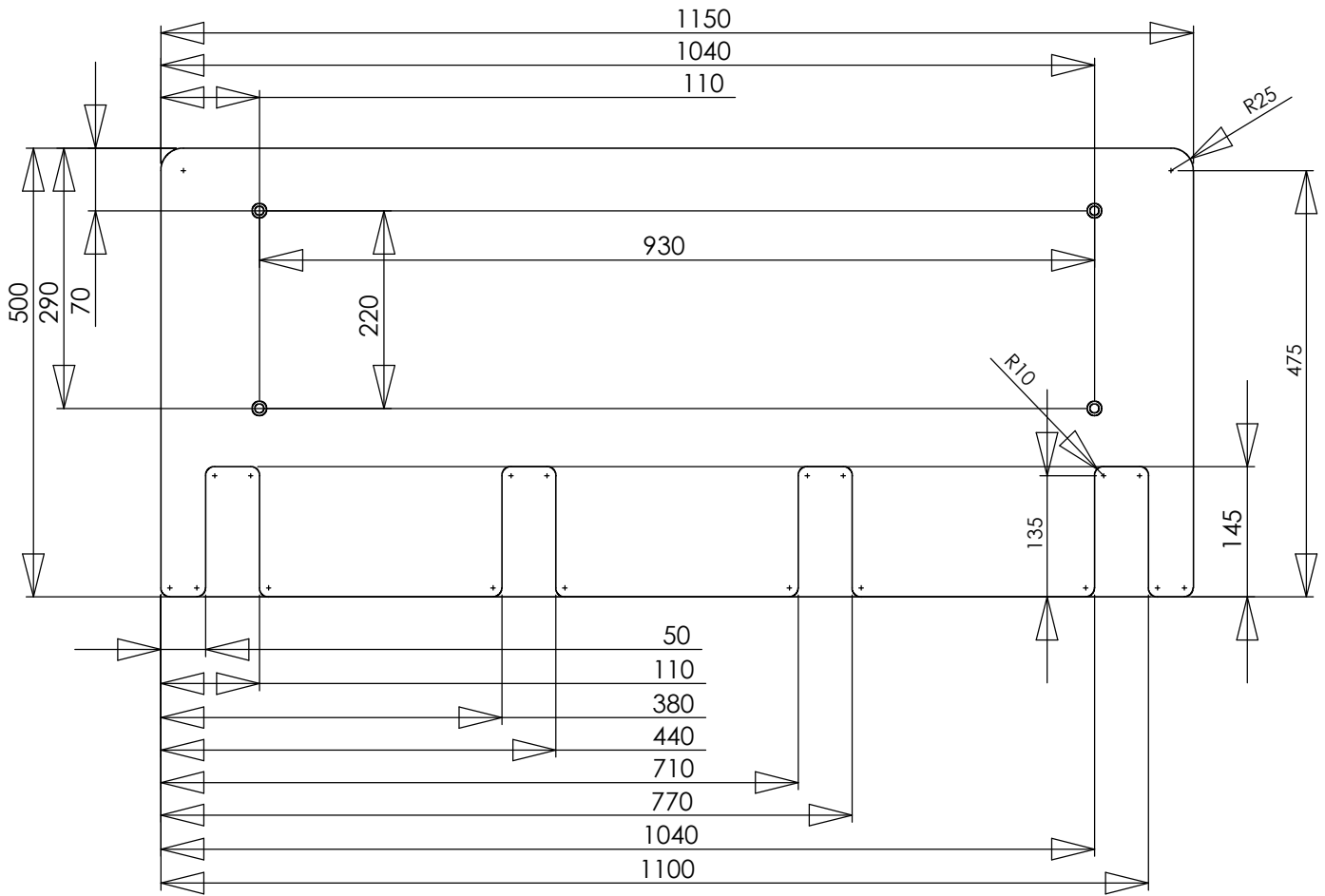

10. Machine table Type E

When machines are placed on a WALKO always follow the manufacturers instructions for this machine.
 Do not make the tables too big, prefer the WALKO for tipping over.
 Work safe, Think twice.
 WALKO-Tools BV can not be held responsible for self made table tops.
 All information on these sheets under the usual reservations of format and printing errors.